



TECHNICAL DATA
FROM
Anemostat[®]
DOOR PRODUCTS
A MESTEK COMPANY

P.O. BOX 4938 • 1220 WATSONCENTER ROAD
CARSON, CA 90745-4206
(310) 835-7500 • FAX (310) 835-0448

e-mail: sales@anemostat.com • website: www.anemostat.com

Lo-FP-12

12" ROUND

LO-PROFILE METAL VISION FRAME



FIRE RATINGS



UNDERWRITERS' LABORATORIES

WARNOCK HERSEY

EN-1634 (pending)
European Standard

B.S.-476.22
British Standard

DETAIL DRAWING

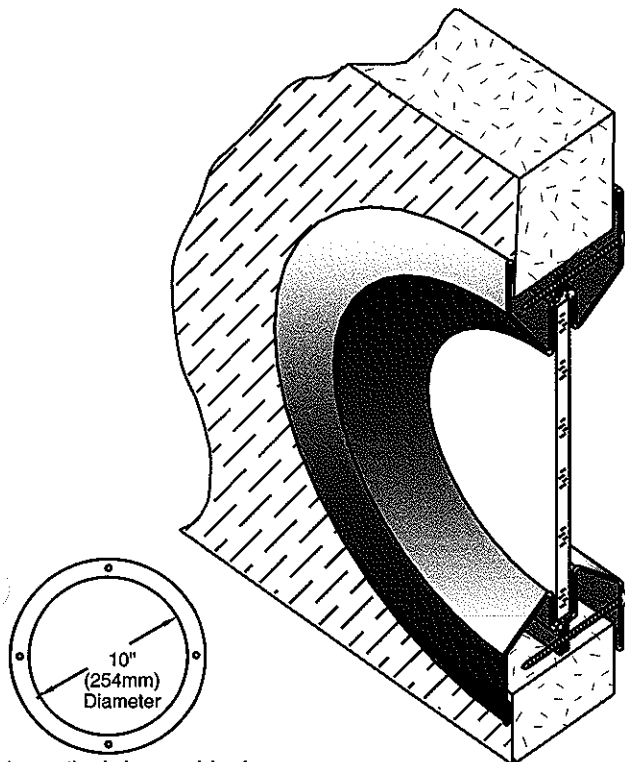

4 mounting holes per vision frame

Anemostat manufacturing dimensions ±1/32
Actual dimensions are nominal and may vary
based on component manufacturers tolerances.

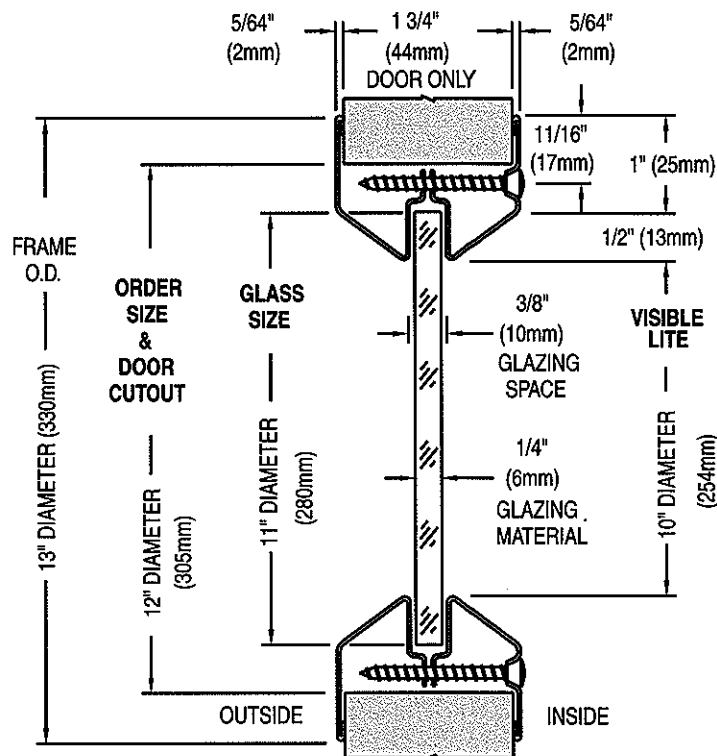

STANDARD PRODUCT FEATURES

- **MATERIAL:** 20 GA. Cold Rolled Steel.
- **FINISH:** Grey Primer, Beige or Bronze Baked Enamel.
- **INSTALLATION:** Uses #8 x 1 3/4" long phillips oval head screws that pass through the door cutout and fasten to the to the opposite side of the vision frame, eliminating the need for thru bolts.
- **DOOR THICKNESS:** For 1 3/4" Wood or Metal Doors.
- **GLASS:** Should be 1/4", 3/16" or 5/16" fire rated with U.L. and/or W.H.I. classification markings. Glazing space of 3/8" allows for glazing tape to be used on both sides of the glass.
- **AESTHETICS:** Smooth round contour of low profile frame style gives a unique design to any setting.
- **IMPORTANT:** Interpretation of building and fire codes may vary. Consult with the local authority having jurisdiction in your area, to determine appropriate standards.
- **NOTE:** For Exterior use, High Humidity or Salt Air application, product must be Galvanized steel.

OPTIONAL FEATURES

- **MATERIAL:** #304 or #316 Stainless Steel, #4 Finish(Satin), Galvanized (Hot Dipped, or Zinc Plated),
- **FINISH:** Custom Baked Enamel Colors (as per sample chip supplied). Plated Finishes to match the lock, hinges and closer.
- **FASTENERS:** Special Security Screw Fasteners, See Page 31, this section.
- **SPECIALS:** Consult Factory for special diameter sizes or special glass or door thickness. (see Lo-FP-12-IS)

FIRE RATINGS (w/ U.L. & W.H.I. classification markings) Positive Pressure

- **20/45/60/90 MINUTE:** Approved listing at 79 sq.in. visible lite.

BS 476.22 Timber Doors - 30 min. and 1 hour. Tested to 254mm x 762mm
British Standard Steel Doors - 2 hours (4 hours actual). Tested to 813mm x 813mm

EN-1634 30/60 min. integrity and insulation - pending
European Std.

Job Name & Location	Submitted by

TECHNICAL DATA

FROM

Anemostat®

DOOR PRODUCTS

A MESTEK COMPANY

P.O. BOX 4938 • 1220 WATSONCENTER ROAD
CARSON, CA 90745-4206

(310) 835-7500 • FAX (310) 835-0448

e-mail: sales@anemostat.com • website: www.anemostat.com

FP-12

12" ROUND METAL VISION FRAME



FIRE RATINGS

UNDERWRITERS' LABORATORIES



WARNOCK HERSEY

DETAIL DRAWING

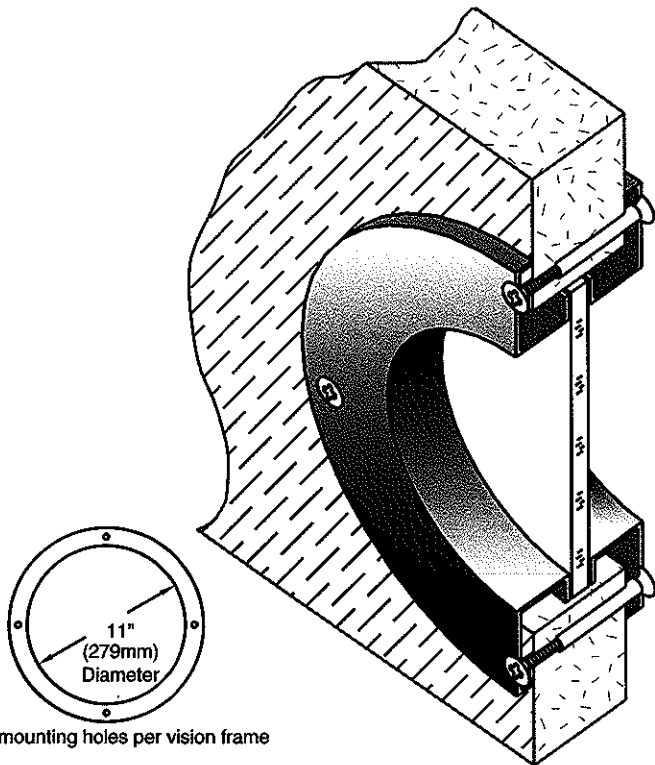

4 mounting holes per vision frame

Anemostat manufacturing dimensions $\pm 1/32$
Actual dimensions are nominal and may vary
based on component manufacturers tolerances.

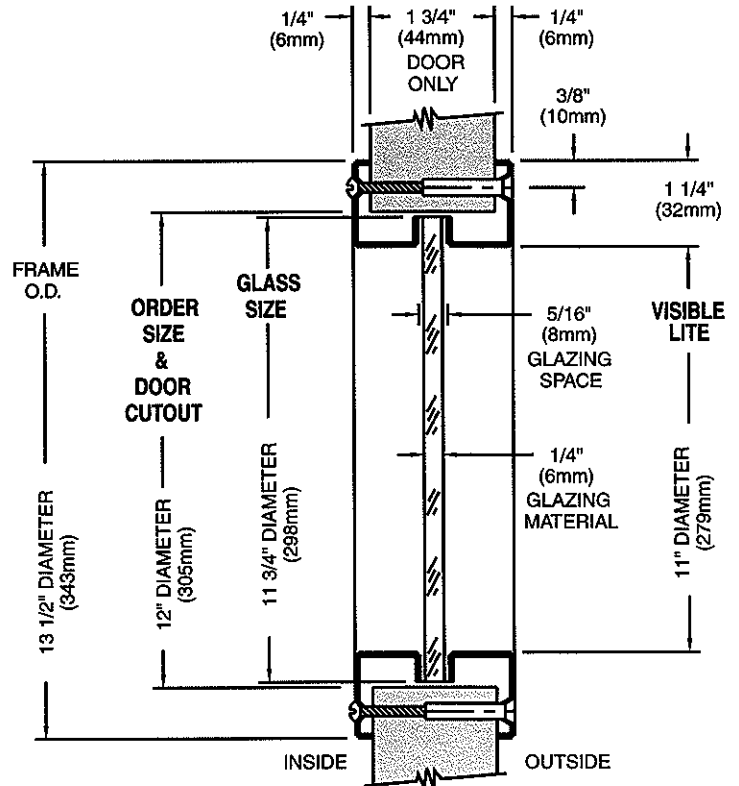

STANDARD PRODUCT FEATURES

- **MATERIAL:** 18 GA. Cold Rolled Steel.
- **FINISH:** Grey Primer, Beige or Bronze Baked Enamel.
- **INSTALLATION:** By drilling 1/4" holes thru the door, around the perimeter of the door cutout. Frame has countersunk mounting holes for #8x32 phillips head steel thru bolts with a blank head on one side for flush appearance.
- **DOOR THICKNESS:** For 1 3/4" Wood and Metal Doors.
- **GLASS:** Should be 1/4" or 3/16" fire rated with U.L. and/or W.H.I. classification markings. Glazing space of 5/16" allows for glazing tape to be used on both sides of the glass.
- **AESTHETICS:** Smooth round contour of frame style gives a unique design to any setting.
- **NOTE:** For Exterior use, High Humidity or Salt Air application, product must be Galvanized or Stainless Steel.

OPTIONAL FEATURES

- **MATERIAL:** #304 or #316 Stainless Steel, #4 Finish(Satin), Galvanized (Hot Dipped, or Zinc Plated).
- **FINISH:** Custom Baked Enamel Colors (as per sample chip supplied). Plated Finishes to match the lock, hinges and closer.
- **FASTENERS:** Special Security Screw Fasteners, See Page 31, this section.
- **SPECIALS:** Lead Lined for X-ray applications, Consult Factory for special diameter sizes and special glass or door thicknesses. (see FP-12-IS)

FIRE RATINGS (w/ U.L. & W.H.I. classification markings) Positive Pressure

- **20/45/60/90 MINUTE:** Approved listing at 95 sq.in. visible lite.
- **IMPORTANT:** Interpretation of building and fire codes may vary. Consult with the local authority having jurisdiction in your area, to determine appropriate standards.

Job Name & Location	Submitted by



TECHNICAL DATA
FROM
Anemostat[®]
DOOR PRODUCTS
A MESTEK COMPANY

P.O. BOX 4938 • 1220 WATSONCENTER ROAD
CARSON, CA 90745-4206
(310) 835-7500 • FAX (310) 835-0448

e-mail: sales@anemostat.com • website: www.anemostat.com

Lo-FP-18

18" ROUND

LO-PROFILE METAL VISION FRAME



FIRE RATINGS



UNDERWRITERS' LABORATORIES

WARNOCK HERSEY

EN-1634 (pending)
European Standard

B.S.-476.22
British Standard

DETAIL DRAWING

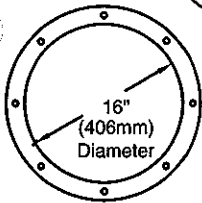
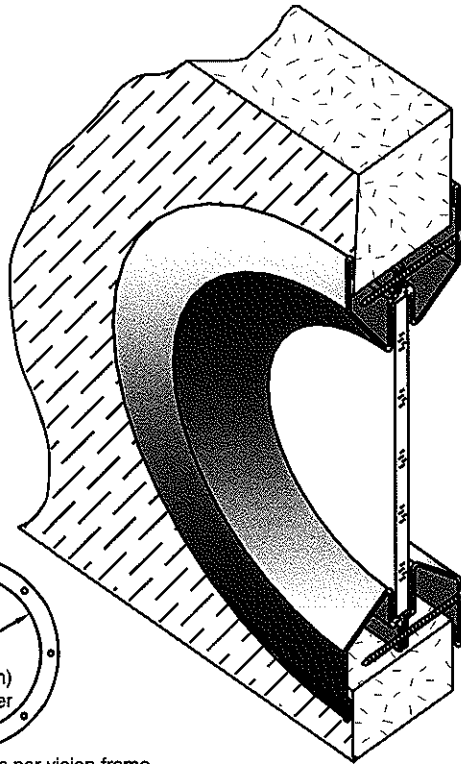

8 mounting holes per vision frame

Anemostat manufacturing dimensions ±1/32
Actual dimensions are nominal and may vary based on component manufacturers tolerances.

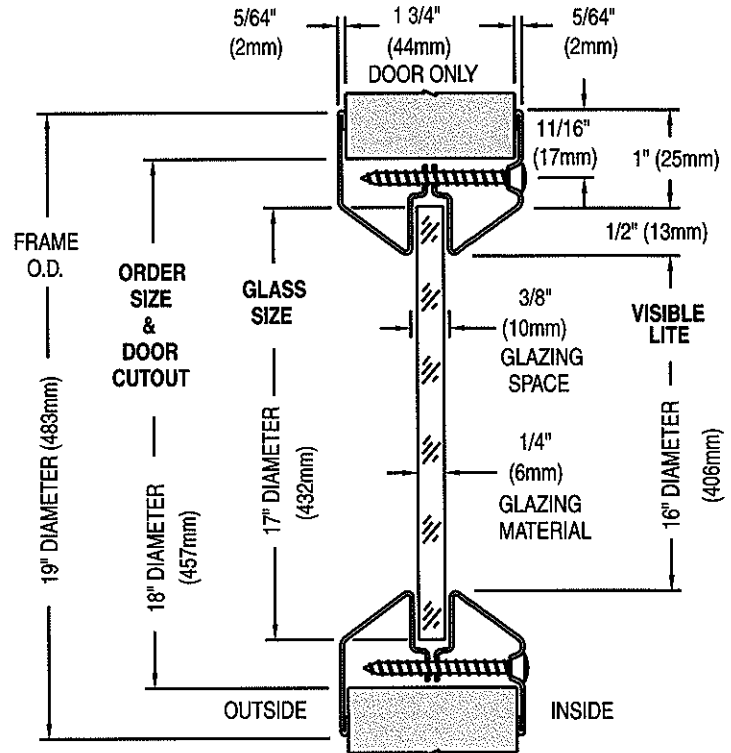

STANDARD PRODUCT FEATURES

- **MATERIAL:** 20 GA. Cold Rolled Steel.
- **FINISH:** Grey Primer, Beige or Bronze Baked Enamel.
- **INSTALLATION:** Uses #8 x 1 3/4" long phillips oval head screws that pass through the door cutout and fasten to the opposite side of the vision frame, eliminating the need for thru bolts.
- **DOOR THICKNESS:** For 1 3/4" Wood or Metal Doors.
- **GLASS:** Should be 1/4", 3/16" or 5/16" fire rated with U.L. and/or W.H.I. classification markings. Glazing space of 3/8" allows for glazing tape to be used on both sides of the glass.
- **AESTHETICS:** Smooth round contour of low profile frame style gives a unique design to any setting.
- **IMPORTANT:** Interpretation of building and fire codes may vary. Consult with the local authority having jurisdiction in your area, to determine appropriate Standards.
- **NOTE:** For Exterior use, High Humidity or Salt Air application, product must be Galvanized steel.

OPTIONAL FEATURES

- **MATERIAL:** #304 or #316 Stainless Steel, #4 Finish (Satin), Galvanized (Hot Dipped, or Zinc Plated).
- **FINISH:** Custom Baked Enamel Colors (as per sample chip supplied). Plated Finishes to match the lock, hinges and closer.
- **FASTENERS:** Special Security Screw Fasteners, See Page 31, this section.
- **SPECIALS:** Consult Factory for special diameter sizes and special glass or door thickness.

FIRE RATINGS (w/ U.L. & W.H.I. classification markings) Positive Pressure

- **20/45/60*/90* MINUTE:** Approved listing at 201 sq.in. visible lite.
* Must be used with FIRELITE Plus or NT and Fire listed glazing tape and be used in appropriately tested door assembly.

BS 476.22 British Standard Timber Doors - 30 min. and 1 hour. Tested to 254mm x 762mm
Steel Doors - 2 hours (4 hours actual). Tested to 813mm x 813mm

EN-1634 European Std. 30/60 min. integrity and insulation - pending

Job Name & Location	Submitted by



TECHNICAL DATA
FROM
Anemostat[®]
DOOR PRODUCTS
A MESTEK COMPANY

P.O. BOX 4938 • 1220 WATSONCENTER ROAD
CARSON, CA 90745-4206
(310) 835-7500 • FAX (310) 835-0448

e-mail: sales@anemostat.com • website: www.anemostat.com

FP-18
18" ROUND
METAL VISION FRAME



UNDERWRITERS'
LABORATORIES

FIRE
RATINGS



WARNOCK
HERSEY

DETAIL DRAWING

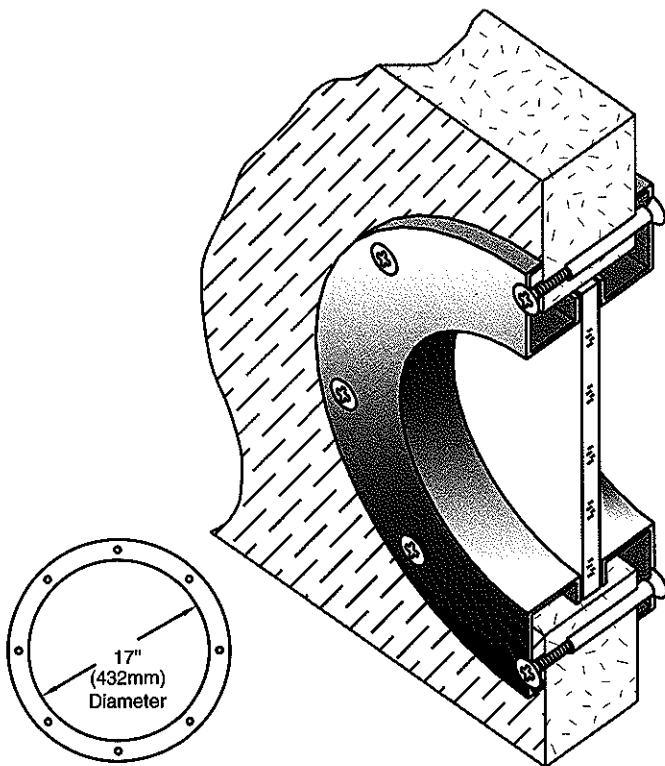

8 mounting holes per vision frame

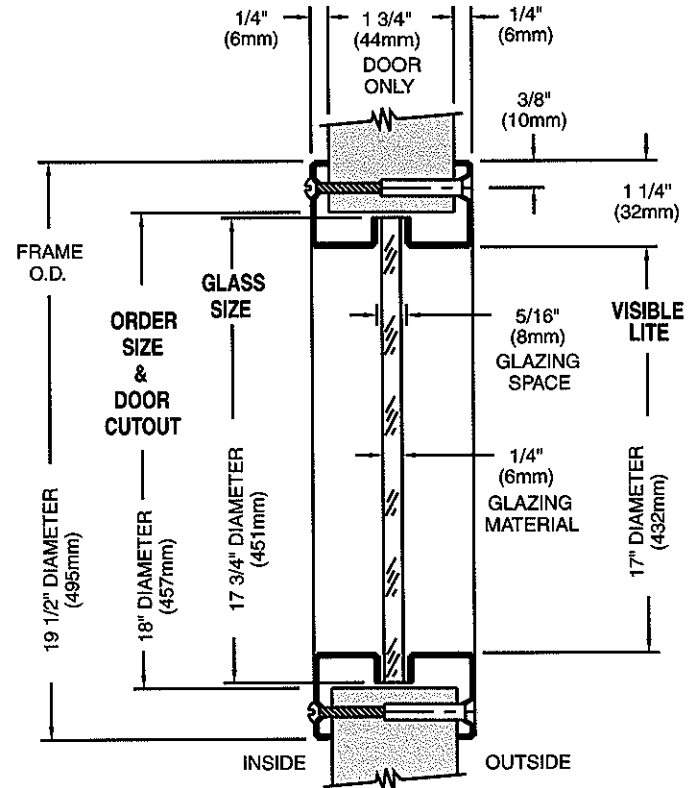
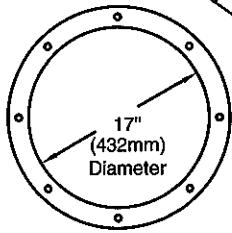

Anemostat manufacturing dimensions ±1/32
Actual dimensions are nominal and may vary
based on component manufacturers tolerances.

STANDARD PRODUCT FEATURES

- **MATERIAL:** 18 GA. Cold Rolled Steel.
- **FINISH:** Grey Primer, Beige or Bronze Baked Enamel.
- **INSTALLATION:** By drilling 1/4" holes thru the door, around the perimeter of the door cutout. Frame has countersunk mounting holes for #8x32 phillips head steel thru bolts with a blank head on one side for flush appearance.
- **DOOR THICKNESS:** For 1 3/4" Wood or Metal Doors.
- **GLASS:** Should be 1/4" or 3/16" fire rated with U.L. and/or W.H.I. classification markings. Glazing space of 5/16" allows for glazing tape to be used on both sides of the glass.
- **AESTHETICS:** Smooth round contour of frame style gives a unique design to any setting.
- **NOTE:** For Exterior use, High Humidity or Salt Air application, product must be Galvanized or Stainless Steel.

OPTIONAL FEATURES

- **MATERIAL:** #304 or #316 Stainless Steel, #4 Finish(Satin), Galvanized (Hot Dipped, or Zinc Plated).
- **FINISH:** Custom Baked Enamel Colors (as per sample chip supplied). Plated Finishes to match the lock, hinges and closer.
- **FASTENERS:** Special Security Screw Fasteners, See Page 31, this section.
- **SPECIALS:** Lead Lined for X-ray applications, Consult Factory for special diameter sizes and special glass or door thicknesses. (see FP-18-IS)

FIRE RATINGS (w/ U.L. & W.H.I. classification markings) Positive Pressure

- **20/45/60*90* MINUTE:** Approved listing at 201 sq.in. visible lite.
* Must be used with FIRELITE NT and Fire listed glazing tape and be used in appropriately tested door assembly.
- **IMPORTANT:** Interpretation of building and fire codes may vary. Consult with the local authority having jurisdiction in your area, to determine appropriate standards.

Job Name & Location	Submitted by

474A101A

For Most Current Info, Consult Factory or check our website, www.anemostat.com

OCTOBER 2004
METAL VISION FRAMES PAGE 14



TECHNICAL DATA
FROM
Anemostat[®]
DOOR PRODUCTS
A MESTEK COMPANY

P.O. BOX 4938 • 1220 WATSONCENTER ROAD
CARSON, CA 90745-4206
(310) 835-7500 • FAX (310) 835-0448

e-mail: sales@anemostat.com • website: www.anemostat.com

Lo-FP-24

24" ROUND

LO-PROFILE METAL VISION FRAME



UNDERWRITERS'
LABORATORIES

WARNOCK
HERSEY

EN-1634 (pending)
European Standard

B.S.-476.22
British Standard

DETAIL DRAWING

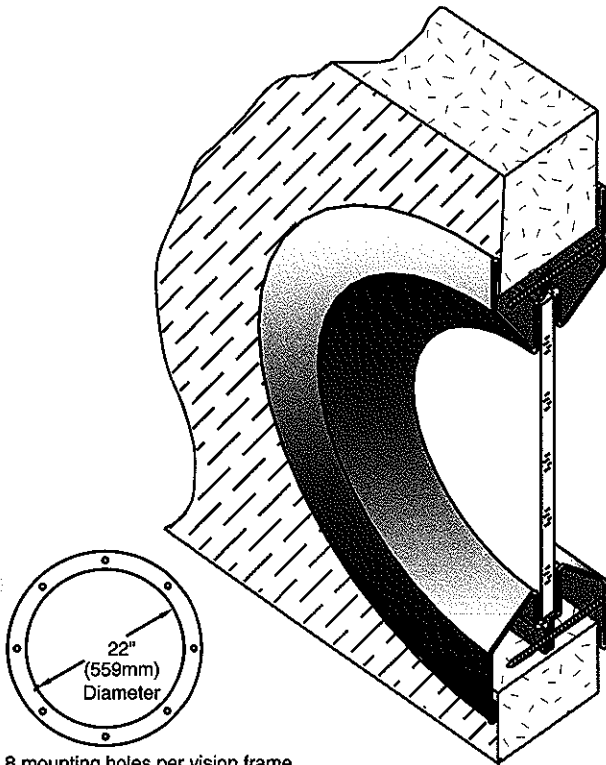

8 mounting holes per vision frame

Anemostat manufacturing dimensions ±1/32
Actual dimensions are nominal and may vary
based on component manufacturers tolerances.

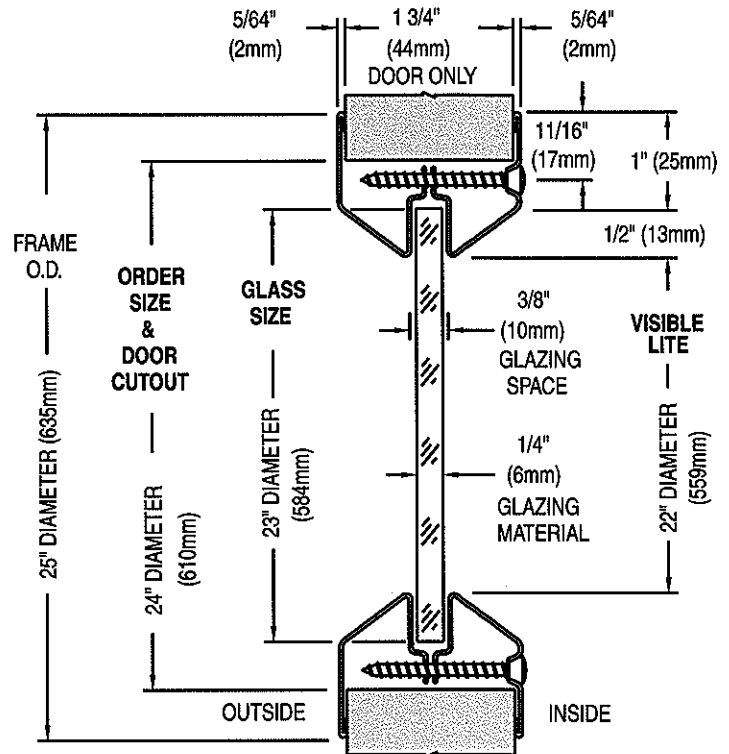

STANDARD PRODUCT FEATURES

- **MATERIAL:** 20 GA. Cold Rolled Steel.
- **FINISH:** Grey Primer, Beige or Bronze Baked Enamel.
- **INSTALLATION:** Uses #8 x 1 3/4" long phillips oval head screws that pass through the door cutout and fasten to the to the opposite side of the vision frame, eliminating the need for thru bolts.
- **DOOR THICKNESS:** For 1 3/4" Wood or Metal Doors.
- **GLASS:** Should be 1/4", 3/16" or 5/16" fire rated with U.L. and/or W.H.I. classification markings. Glazing space of 3/8" allows for glazing tape to be used on both sides of the glass.
- **AESTHETICS:** Smooth round contour of low profile frame style gives a unique design to any setting.
- **IMPORTANT:** Interpretation of building and fire codes may vary. Consult with the local authority having jurisdiction in your area, to determine appropriate standards.
- **NOTE:** For Exterior use, High Humidity or Salt Air application, product must be Galvanized steel.

OPTIONAL FEATURES

- **MATERIAL:** #304 or #316 Stainless Steel, #4 Finish(Satin), Galvanized (Hot Dipped, or Zinc Plated).
- **FINISH:** Custom Baked Enamel Colors (as per sample chip supplied). Plated Finishes to match the lock, hinges and closer.
- **FASTENERS:** Special Security Screw Fasteners, See Page 31, this section.
- **SPECIALS:** Consult Factory for special diameter sizes and special glass or door thickness. (see Lo-FP-24-IS)

FIRE RATINGS (w/ U.L. & W.H.I. classification markings) Positive Pressure

- **20/45/60*90* MINUTE:** Approved listing at 380 sq.in. visible lite.

* Must be used with FIRELITE Plus or NT and Fire listed glazing tape and be used in appropriately tested door assembly.

BS 476.22 Timber Doors - 30 min. and 1 hour. Tested to 254mm x 762mm
British Standard Steel Doors - 2 hours (4 hours actual). Tested to 813mm x 813mm

EN-1634 30/60 min. integrity and insulation - pending
European Std.

Job Name & Location	Submitted by

TECHNICAL DATA

FROM

Anemostat®

DOOR PRODUCTS

A MESTEK COMPANY

P.O. BOX 4938 • 1220 WATSONCENTER ROAD
CARSON, CA 90745-4206
(310) 835-7500 • FAX (310) 835-0448

e-mail: sales@anemostat.com • website: www.anemostat.com



FP-24

24" ROUND METAL VISION FRAME



UNDERWRITERS'
LABORATORIES

FIRE
RATINGS



WARNOCK
HERSEY

DETAIL DRAWING

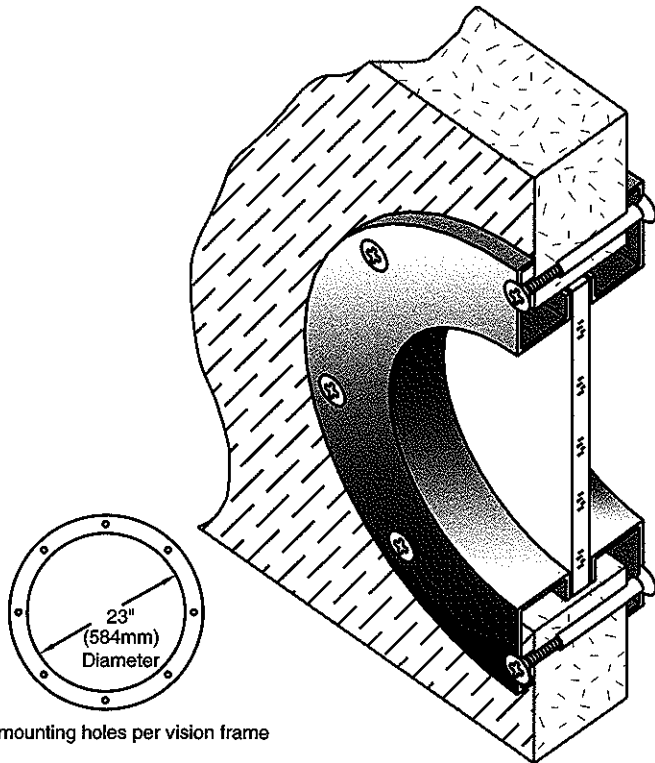

8 mounting holes per vision frame

Anemostat manufacturing dimensions $\pm 1/32$
Actual dimensions are nominal and may vary
based on component manufacturers tolerances.

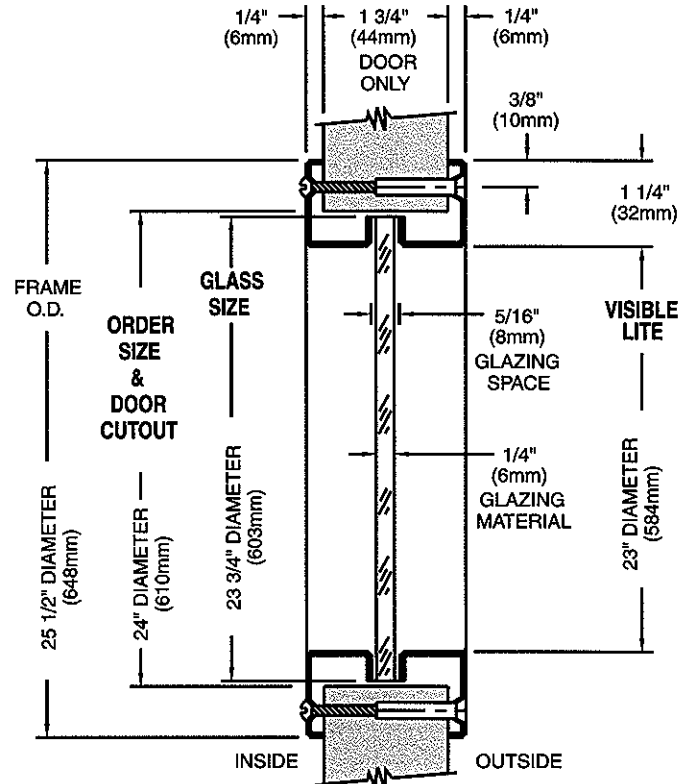

STANDARD PRODUCT FEATURES

- **MATERIAL:** 18 GA. Cold Rolled Steel.
- **FINISH:** Grey Primer, Beige or Bronze Baked Enamel.
- **INSTALLATION:** By drilling 1/4" holes thru the door, around the perimeter of the door cutout. Frame has countersunk mounting holes for #8x32 phillips head steel thru bolts with a blank head on one side for flush appearance.
- **DOOR THICKNESS:** For 1 3/4" Wood or Metal Doors.
- **GLASS:** Should be 1/4" or 3/16" fire rated with U.L. and/or W.H.I. classification markings. Glazing space of 5/16" allows for glazing tape to be used on both sides of the glass.
- **AESTHETICS:** Smooth round contour of frame style gives a unique design to any setting.
- **NOTE:** For Exterior use, High Humidity or Salt Air application, product must be Galvanized or Stainless Steel.

OPTIONAL FEATURES

- **MATERIAL:** #304 or #316 Stainless Steel, #4 Finish(Satin), Galvanized (Hot Dipped or Zinc Plated).
- **FINISH:** Custom Baked Enamel Colors (as per sample chip supplied). Plated Finishes to match the lock, hinges and closer.
- **FASTENERS:** Special Security Screw Fasteners, See Page 31, this section.
- **SPECIALS:** Lead Lined for X-ray applications, Consult Factory for special diameter sizes and special glass or door thicknesses. (see FP-24-IS)

FIRE RATINGS (w/ U.L. & W.H.I. classification markings) Positive Pressure

- **20/45/60*/90*** MINUTE: Approved listing at 380 sq.in. visible lite.

* Must be used with FIRELITE NT and Fire listed glazing tape and be used in appropriately tested door assembly.

- **IMPORTANT:** Interpretation of building and fire codes may vary. Consult with the local authority having jurisdiction in your area, to determine appropriate standards.

Job Name & Location	Submitted by

474A100A

For Most Current Info, Consult Factory or check our website, www.anemostat.com

OCTOBER 2004
METAL VISION FRAMES PAGE 16